

4

3

2

1

D

D

C

C

B

B

A

A

Note 1

Network Bias Resistors are Mandatory!  
They should be mounted to the Master's Modbus Terminal Strip. Resistors should be >500 Ohms and <=1000 Ohms. Use values 500-600 Ohms for networks with more than 7 Slaves. Use 1000 Ohms for 7 or less slaves on the network

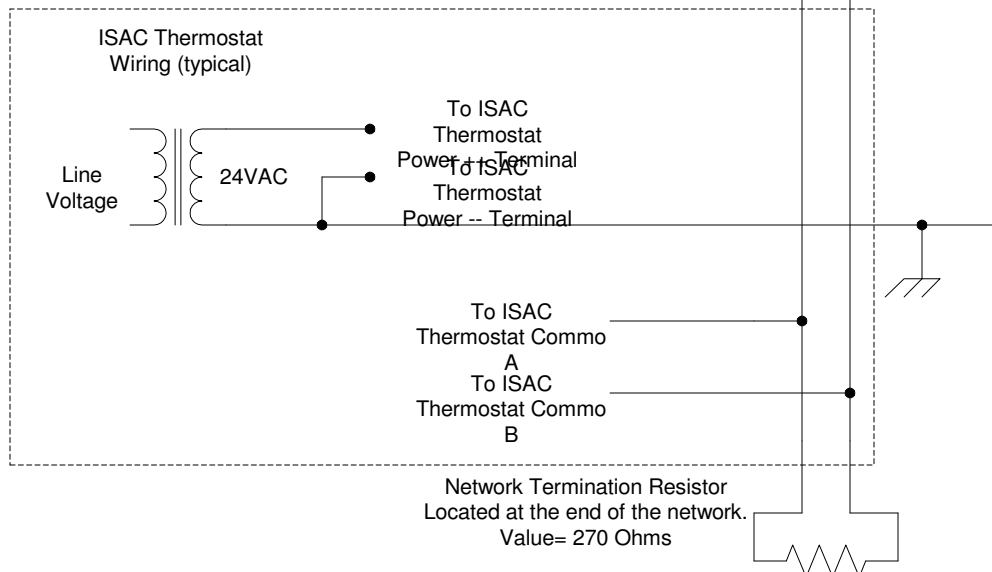
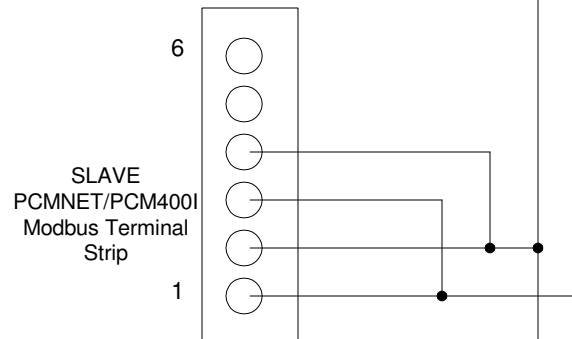
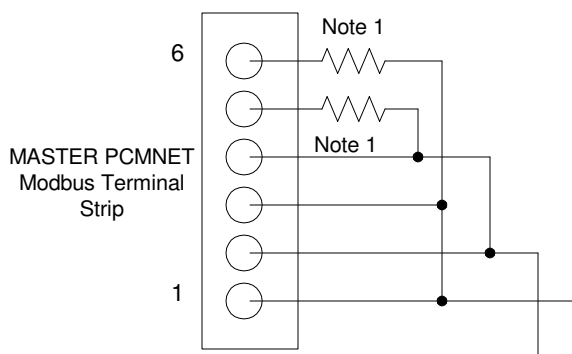

To RET of ISAC PCMNET Boards (ALL PCMNET boards must share a common RET DC Ground. This common RET DC Ground should be connected to Building Protective Ground at the Power Supply of each PCMNET

PCMNET and PCM400 preferred Modbus Connection Wiring Diagram

To properly terminate the Modbus RS485 network and minimize data errors, this is the preferred connection and termination.

- Rev F, 4/5/2006, added HMI 520, Sht 4
- Rev E, 3/3/2004, added MCB80-Modbus, Sht 3
- Rev D, 10/9/2003, added Hussmann Disp, Sht 3
- Rev C, 6/6/2003, added Opto22 B3000 Wiring, Sht 2
- Rev B, 3/9/2003, added Maple Systems Wiring, Sht 2

Modbus RS485 Connections for the PCMNET		SIZE	FSCM NO	DWG NO	REV
DRAWN	RLF	A		Modbus Wiring Diagram.vsd	F
ISSUED	4/5/2006	SCALE	1 : 1	SHEET	1 OF 4

4

3

2

1

4 | 3 | 2 | 1

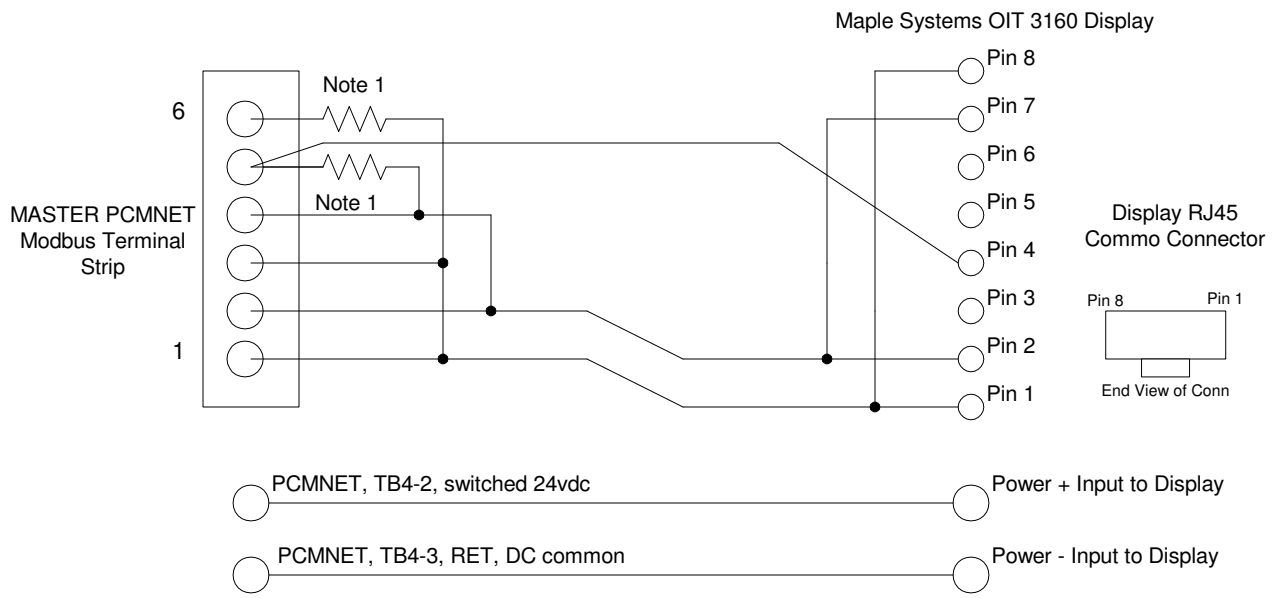

Typical Connection from PCMNET to Maple Systems OIT Display, RS485, 3-wire configuration

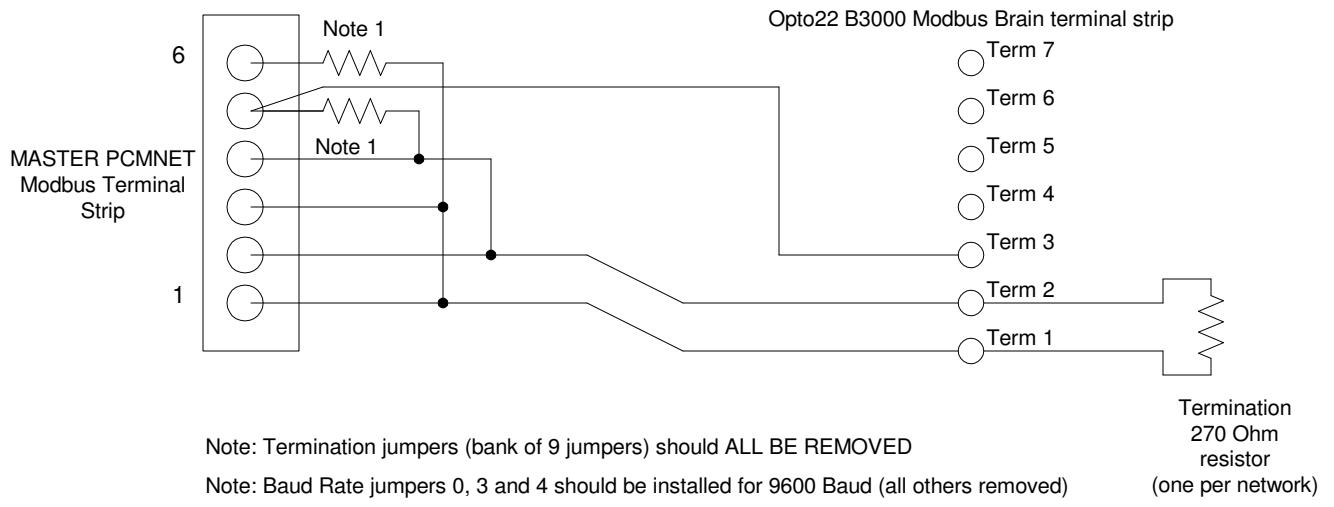

Note: Termination jumpers (bank of 9 jumpers) should ALL BE REMOVED  
 Note: Baud Rate jumpers 0, 3 and 4 should be installed for 9600 Baud (all others removed)  
 Note: Address jumpers set per Opto22 B3000 documentation  
 Example: For address 2, install jumper 1 only (note, jumper numbering starts with 0)

Typical Connection from PCMNET to Opto22 B3000, RS485, 3-wire configuration

Modbus RS485 Connections for the PCMNET			
DRAWN	RLF	SIZE	A
ISSUED	4/5/2006	FSCM NO	
		SCALE	1 : 1
		DWG NO	Modbus Wiring Diagram.vsd
		SHEET	2 OF 4
		REV	F

4 | 3 | 2 | 1

4

3

2

1

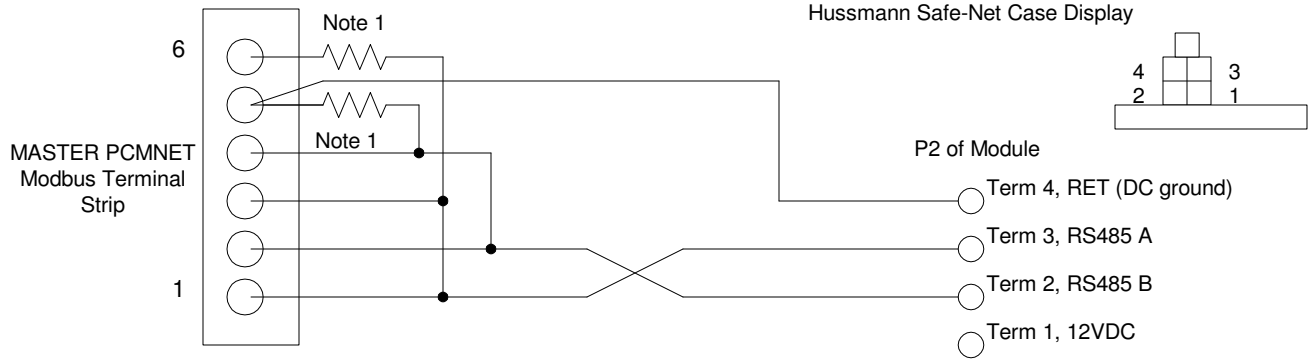

Note: P1 can also be used to connect the RS485 network.  
 P1-1 = RS485 B  
 P1-5 = RS485 A  
 P1-4 = DC RET (RET for board power and RS485 RET)  
 P1-8 = 12VDC (Power to board)

Typical Connection from PCMNET to Hussmann Safe-Net, RS485, 3-wire configuration

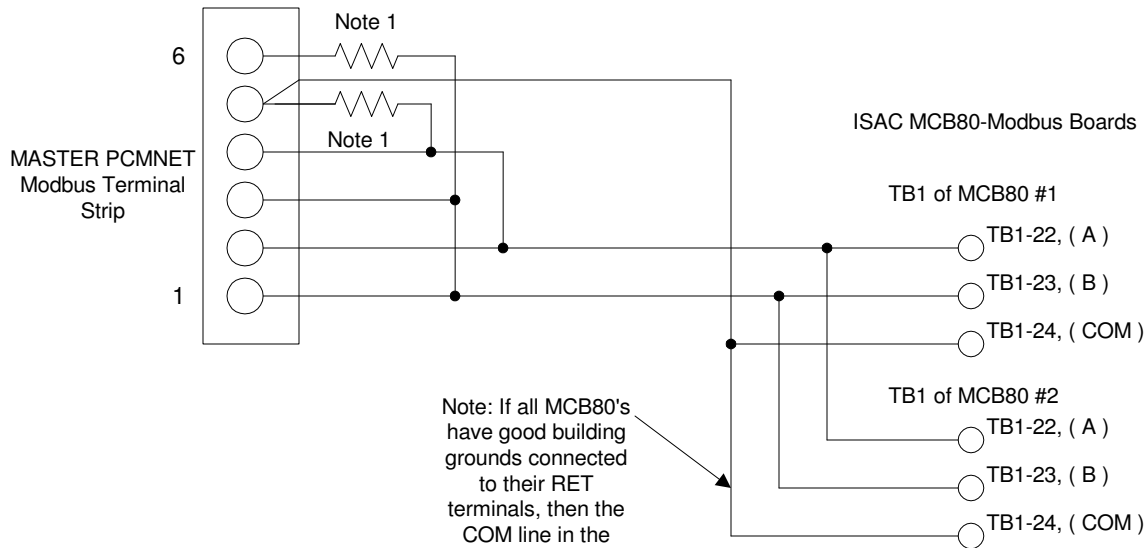

Note: If all MCB80's have good building grounds connected to their RET terminals, then the COM line in the communications cable can be removed and only two (2) lines used for RS232.

Typical Connection from PCMNET to ISAC MCB80-Modbus, RS485, 3-wire configuration

Modbus RS485 Connections for the PCMNET				SIZE	FSCM NO	DWG NO	REV
DRAWN	RLF	A		Modbus Wiring Diagram.vsd		F	
ISSUED	4/5/2006	SCALE	1 : 1	SHEET	3 OF 4		

4

3

2

1

4

3

2

1

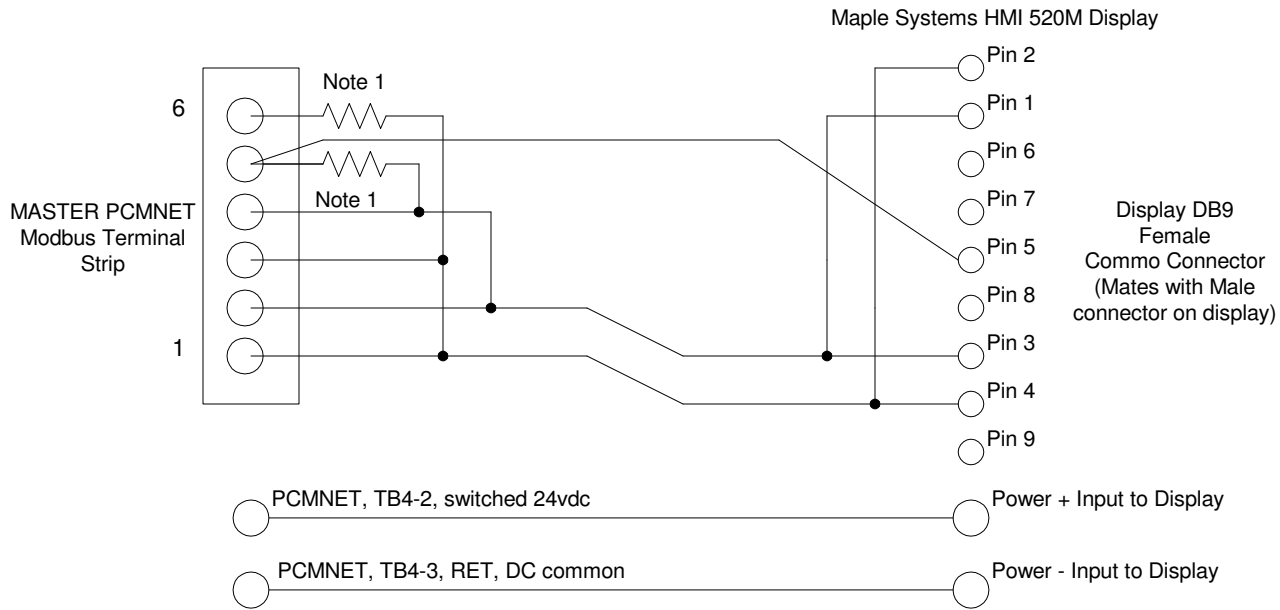

Typical Connection from PCMNET to Maple Systems HMI 520M Display, RS485, 3-wire configuration

D

D

C

C

B

B

A

A

Modbus RS485 Connections for the PCMNET			
DRAWN	RLF	SIZE A	FSCM NO
ISSUED	4/5/2006	SCALE 1 : 1	DWG NO Modbus Wiring Diagram.vsd
		SHEET	REV F
		4 OF 4	

4

3

2

1